

GMS SERİSİ

GMS SERIES

GMS (24-20-16)

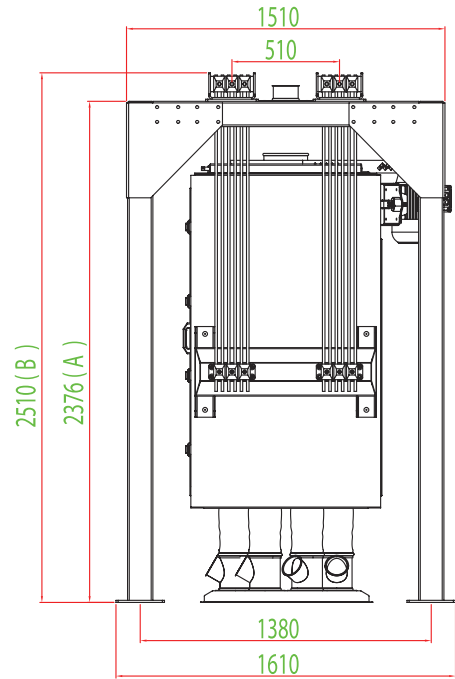
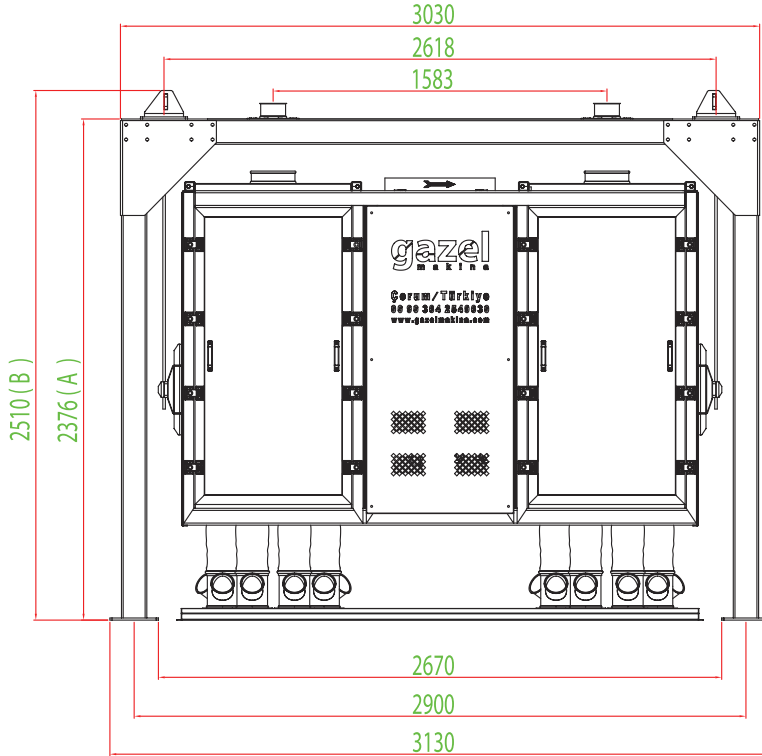
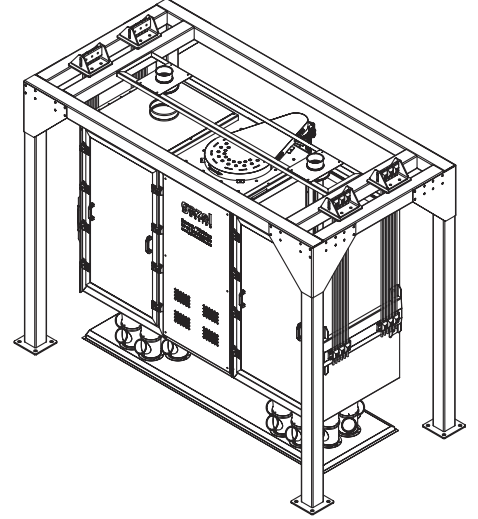
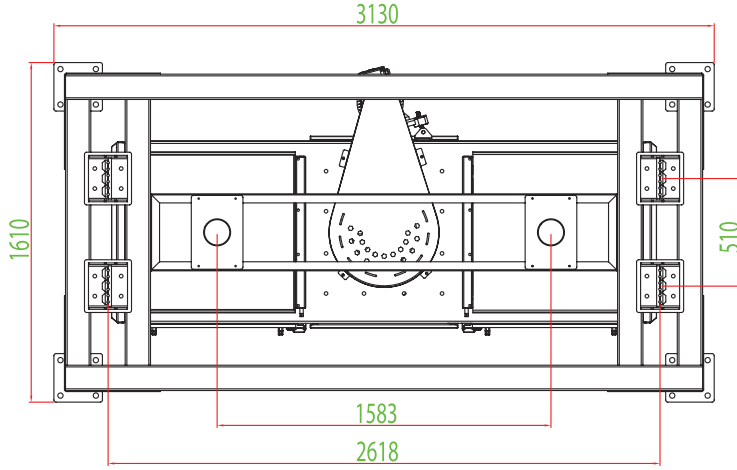

Tip Type	Pasaj Sayısı Number of Section	Ölçüler Measures (mm)		Her Pasajdaki Elek Sayısı Number of Sieves per Section	Toplam Kasa Yüksekliği Total Height of Sieves	Yaklaşık Eleme Alanı (m ²) Approximate Sifting Area (m ²)				Motor Devri Engine Speed (rpm)	Makine Devri Machine Speed (rpm)	Motor kw Engine kw	Makine Çalışma Dairesi Çapı Machine Working Circle Diameter (mm)	Yaklaşık Ağırlık Approximate Weight (KG)
		A	B			G TİP-W TYPE		N TİP-N TYPE						
						Max	Min	Max	Min					
GMS 2/24	2	2676	2810	24-20	169	23,16	19,30	19,30	16,08	1000	245	3	65	3200
GMS 2/20	2	2376	2510	20-16	139	19,30	15,44	16,08	12,86	1000	245	2,2	65	2800
GMS 2/16	2	2076	2210	16-12	109	15,44	11,58	12,86	9,65	1000	245	2,2	65	2350