

EKSTRA PASAJLI  
640 x 640 KASALI ELEK

EXTRA SECTION  
WITH 640 x 640 SIEVES

**GM+**  
Serisi

**GM+**  
Series

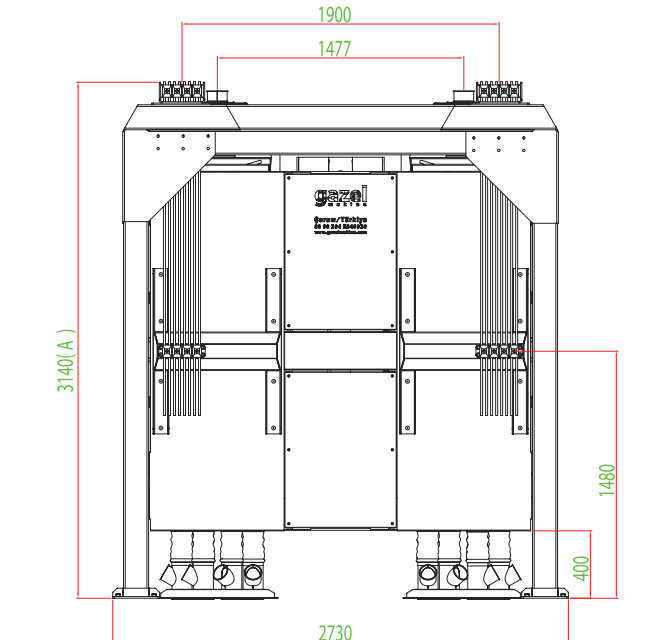
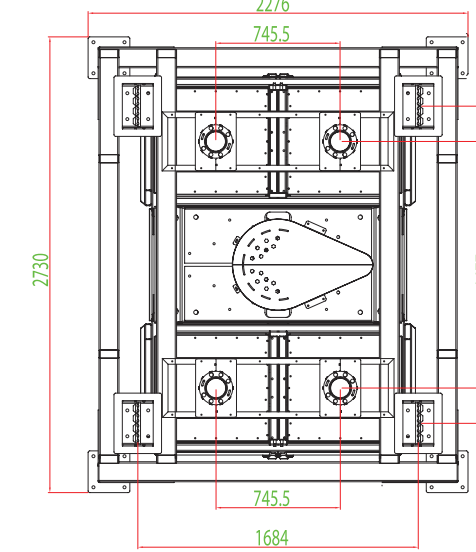
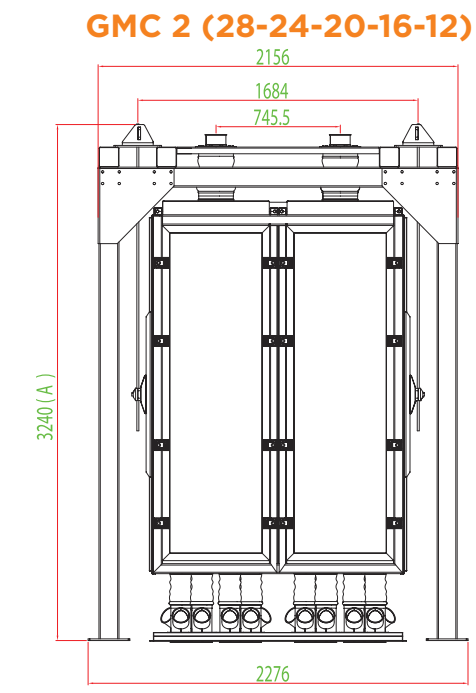
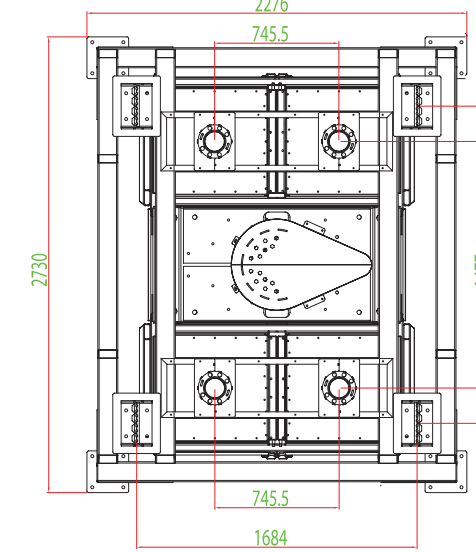
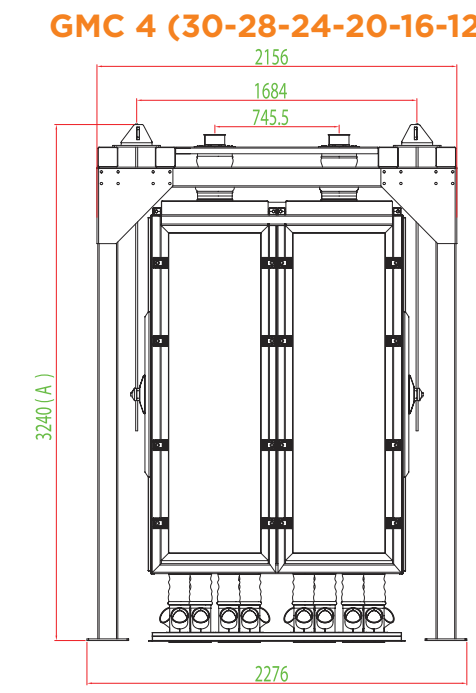
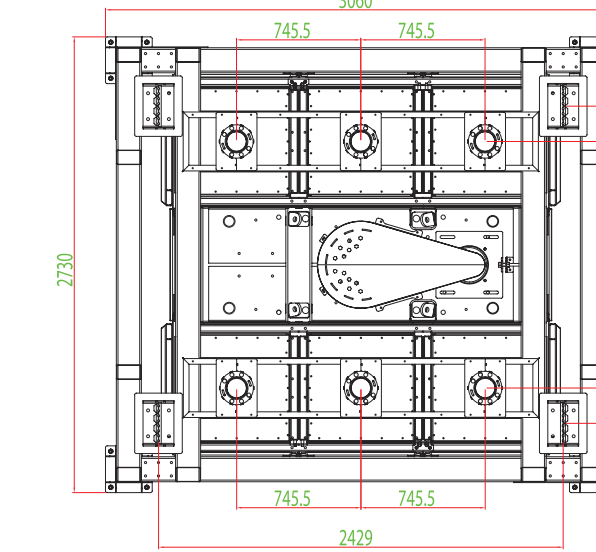
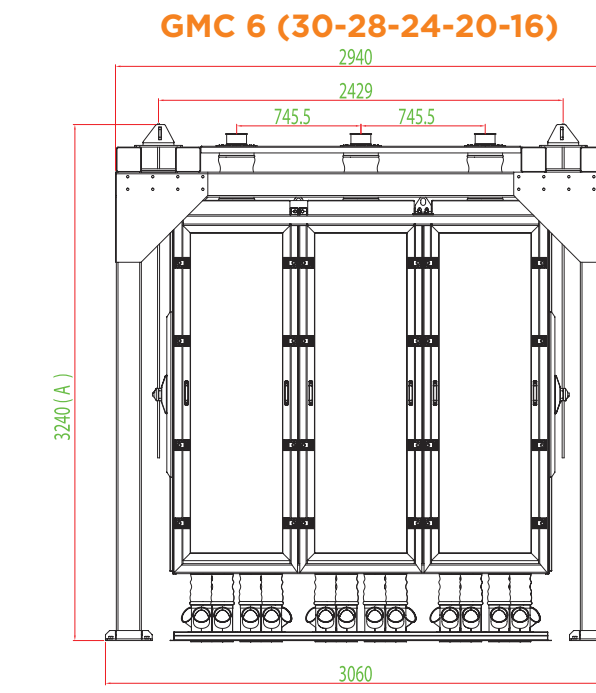
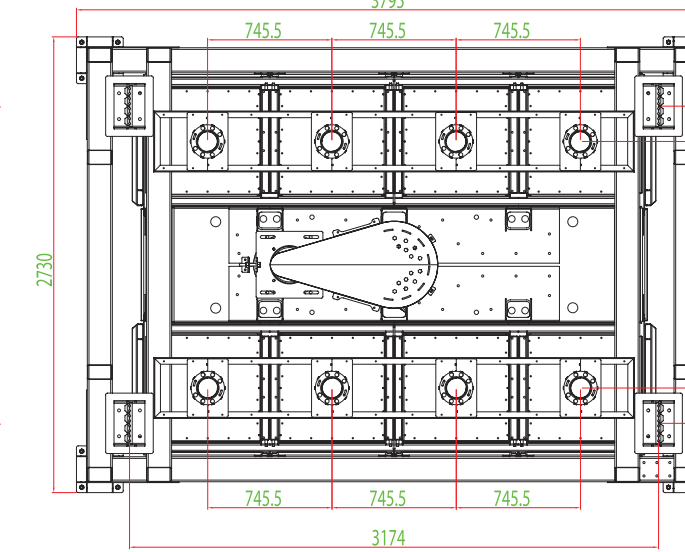
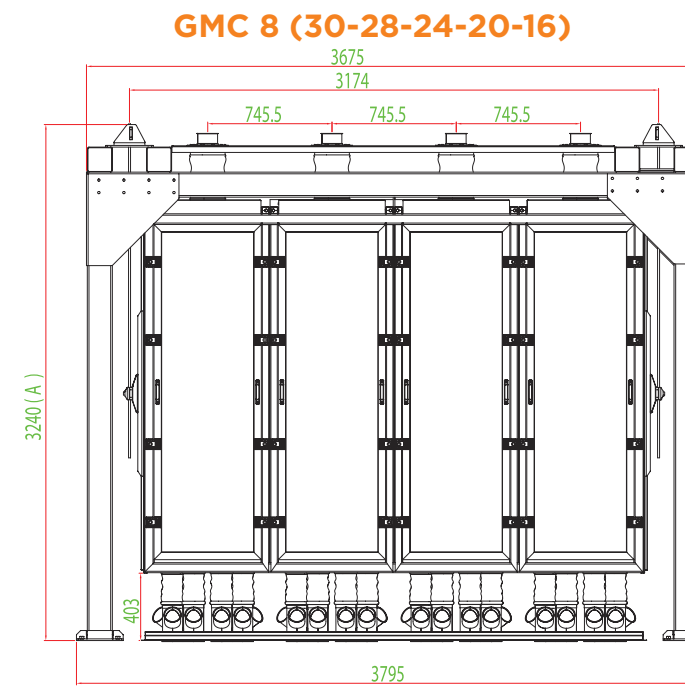
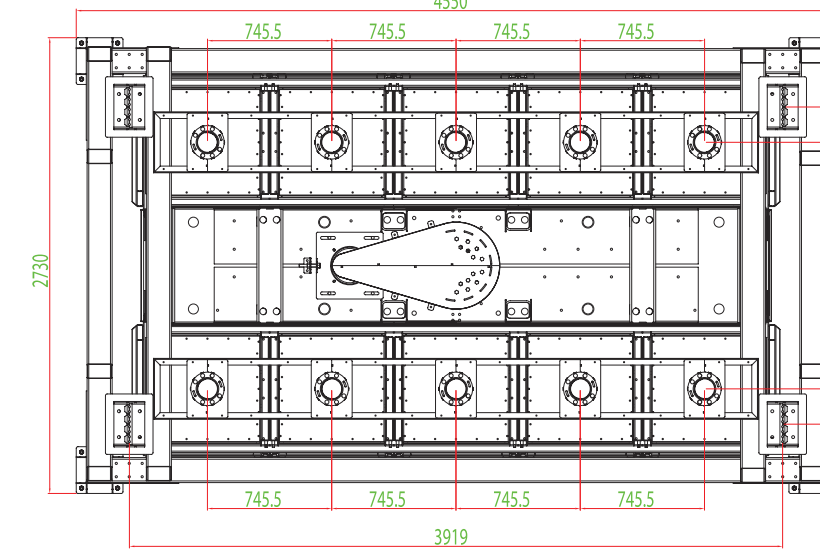
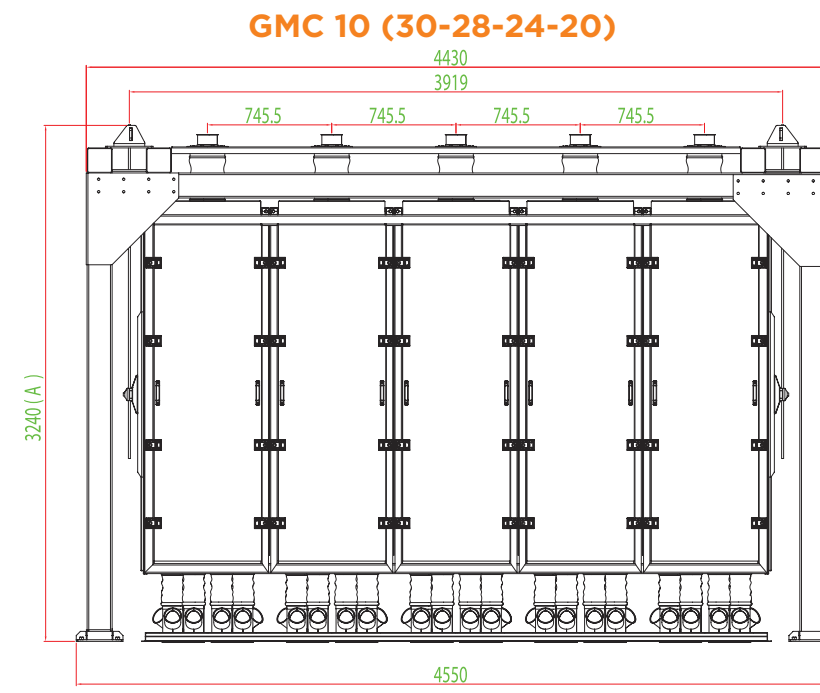
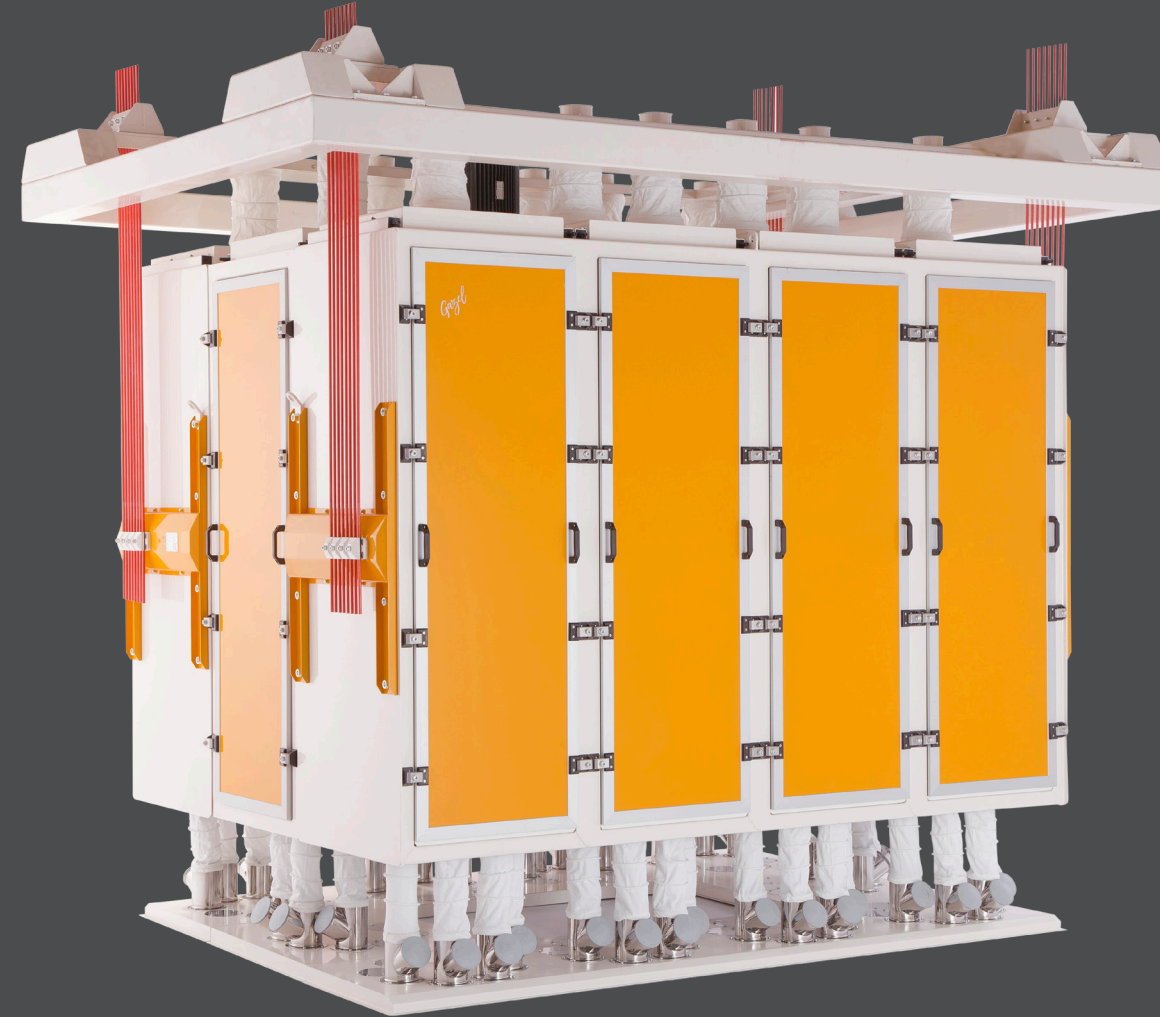

GMC 10-8-6													
Tip Type	Pasaj Sayısı Number of Section	Ölçüler Measures (mm) A	Her Pasajdaki Elek Sayısı Number of Sieves per Section	Toplam Kasa Yüksekliği Total Height of Sieves	Yaklaşık Eleme Alanı (m <sup>2</sup> ) Approximate Sifting Area (m <sup>2</sup> )				Motor Devri Engine Speed (rpm)	Makine Devri Machine Speed (rpm)	Motor kw Engine kw	Makine Çalışma Dairesi Çapı Machine Working Circle Diameter (mm)	Yaklaşık Ağırlık Approximate Weight (KG)
					G TİP-W TYPE		N TİP-N TYPE						
					Max	Min	Max	Min					
GMC 10/30	10	3240	30-26	214	106,02	91,88	85,50	74,10	1000	245	7,5	65	6880
GMC 10/28	10	3090	28-24	199	98,95	84,82	79,80	68,40	1000	245	7,5	65	6610
GMC 10/24	10	2790	24-20	169	84,82	70,68	68,40	57,00	1000	245	7,5	65	6140
GMC 10/20	10	2490	20-16	139	70,68	56,54	57,00	45,60	1000	245	5,5	65	5670
GMC 8/30	8	3240	30-26	214	84,82	73,51	68,40	59,28	1000	245	7,5	65	5800
GMC 8/28	8	3090	28-24	199	79,16	67,85	63,84	54,72	1000	245	5,5	65	5510
GMC 8/24	8	2790	24-20	169	67,85	56,54	54,72	45,60	1000	245	5,5	65	4990
GMC 8/20	8	2490	20-16	139	56,54	45,24	45,60	36,48	1000	245	5,5	65	4350
GMC 8/16	8	2190	16-12	109	45,24	33,93	36,48	27,36	1000	245	4	65	3890
GMC 6/30	6	3240	30-26	214	63,61	55,13	51,30	44,46	1000	245	5,5	65	4770
GMC 6/28	6	3090	28-24	199	59,37	50,89	47,88	41,04	1000	245	4	65	4560
GMC 6/24	6	2790	24-20	169	50,89	42,41	41,04	34,20	1000	245	4	65	4140
GMC 6/20	6	2490	20-16	139	42,41	33,93	34,20	27,36	1000	245	4	65	3720
GMC 6/16	6	2190	16-12	109	33,93	25,44	27,36	20,52	1000	245	4	65	3300

GMC 4-2													
Tip Type	Pasaj Sayısı Number of Section	Ölçüler Measures (mm) A	Her Pasajdaki Elek Sayısı Number of Sieves per Section	Toplam Kasa Yüksekliği Total Height of Sieves	Yaklaşık Eleme Alanı (m <sup>2</sup> ) Approximate Sifting Area (m <sup>2</sup> )				Motor Devri Engine Speed (rpm)	Makine Devri Machine Speed (rpm)	Motor kw Engine kw	Makine Çalışma Dairesi Çapı Machine Working Circle Diameter (mm)	Yaklaşık Ağırlık Approximate Weight (KG)
					G TİP-W TYPE		N TİP-N TYPE						
					Max	Min	Max	Min					
GMC 4/30	4	3240	30-26	214	42,41	36,75	34,20	29,64	1000	245	4	65	3550
GMC 4/28	4	3090	28-24	199	39,58	33,93	31,92	27,36	1000	245	3	65	3400
GMC 4/24	4	2790	24-20	169	33,93	28,27	27,36	22,80	1000	245	3	65	3100
GMC 4/20	4	2490	20-16	139	28,27	22,62	22,80	18,24	1000	245	3	65	2800
GMC 4/16	4	2190	16-12	109	22,62	16,96	18,24	13,68	1000	245	3	65	2500
GMC 4/12	4	1890	12-8	79	16,96	11,31	13,68	9,12	1000	245	3	65	2200
GMC 2/28	2	3090	28-24	199	19,79	16,96	15,96	13,68	1000	245	2,2	65	2600
GMC 2/24	2	2790	24-20	169	16,96	14,14	13,68	11,40	1000	245	2,2	65	2300
GMC 2/20	2	2490	20-16	139	14,14	11,31	11,40	9,12	1000	245	2,2	65	1975
GMC 2/16	2	2190	16-12	109	11,31	8,48	9,12	6,84	1000	245	2,2	65	1650
GMC 2/12	2	1890	12-8	79	8,48	5,65	6,84	4,56	1000	245	2,2	65	1450

**GMC SERİSİ  
PROFİL ŞASELİ  
640 x 640**

**GMC SERIES  
WITH CHASSIS  
640 x 640**