

PROFİL ŞASELİ
640 x 640 KASALI ELEK

INCLUDING CHASSIS
WITH 640 x 640 SIEVES

GMC
Serisi

GMC
Series

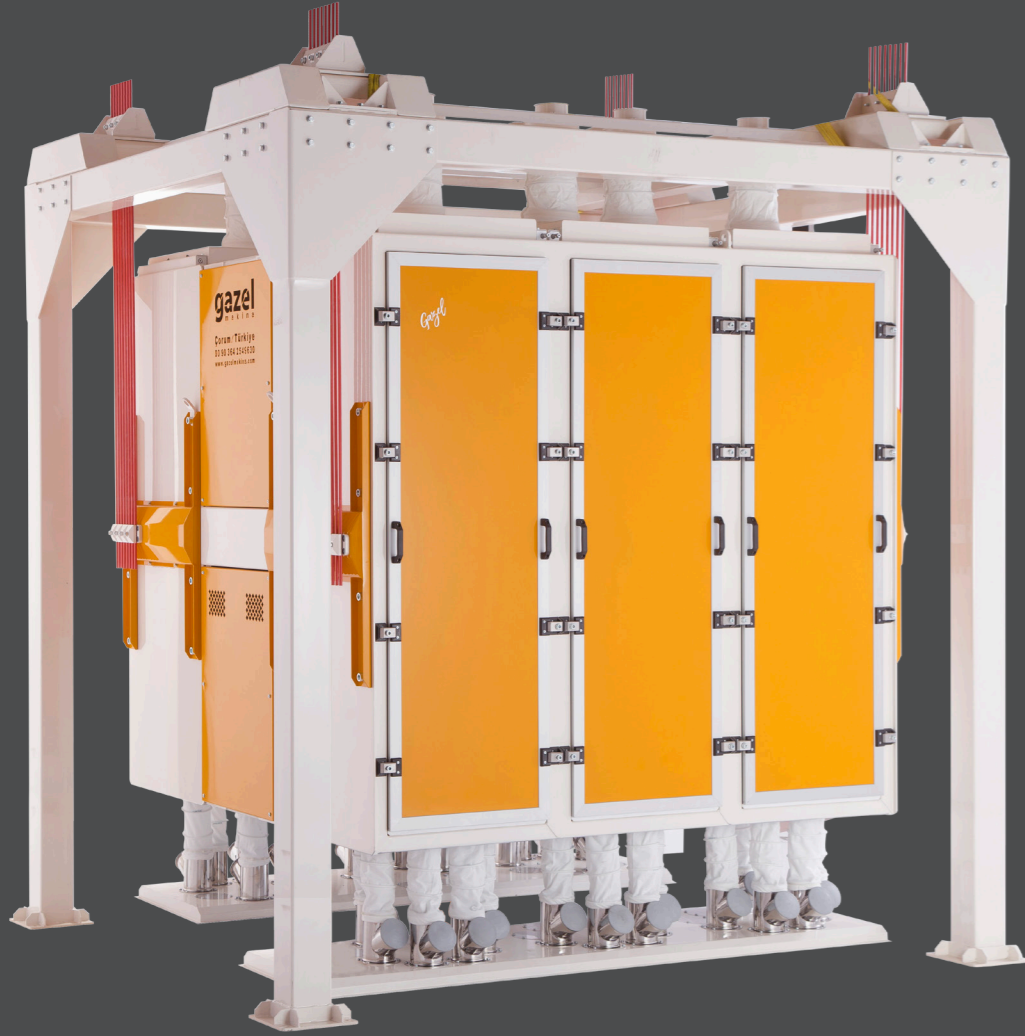

gazel
milling

**GMA 1000
SERİSİ**

**GMA 1000
SERIES**

**GMA 740
SERİSİ**

**GMA 740
SERIES**

**GMAD 740
SERİSİ**

**GMAD 740
SERIES**

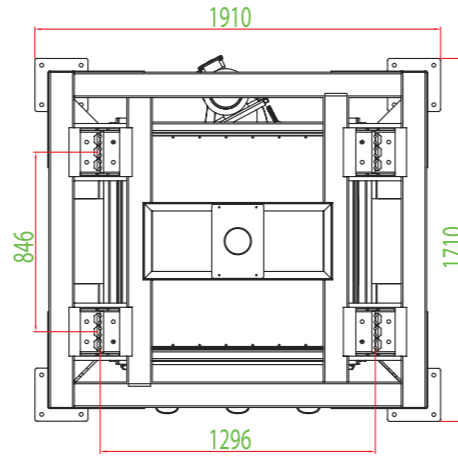

**GMA 1000
(12-8)**

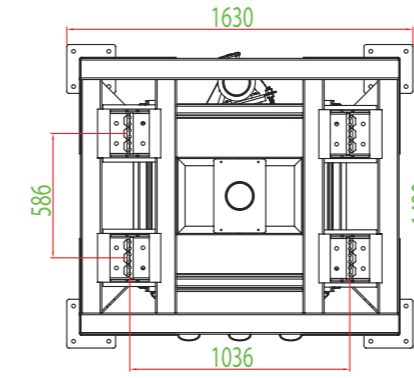

**GMA 740
(12-8)**

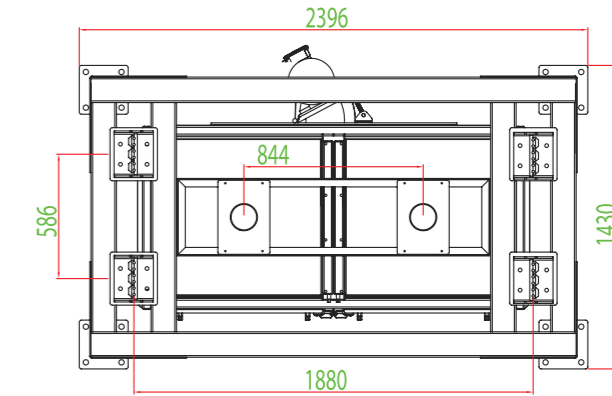

**GMAD 740
(12-8)**

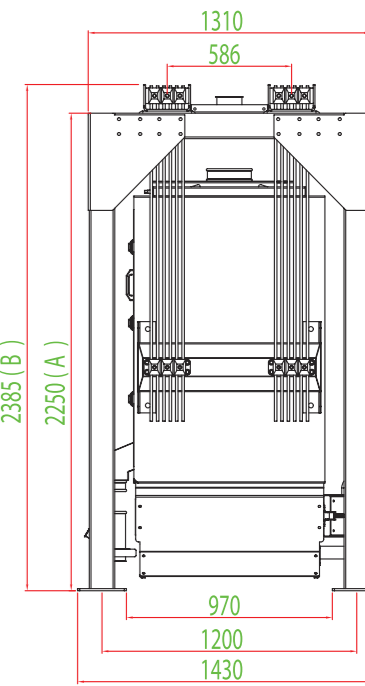
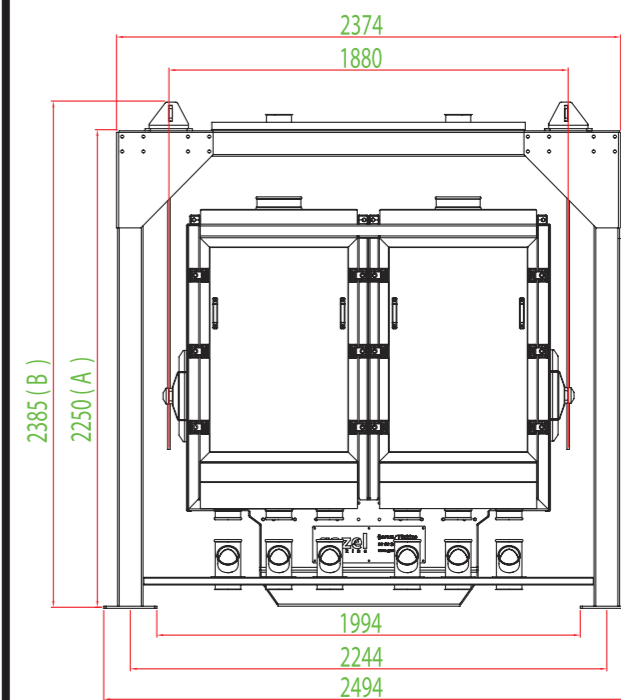
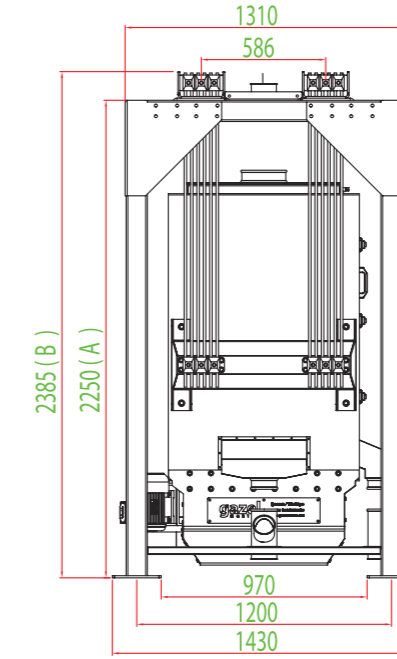
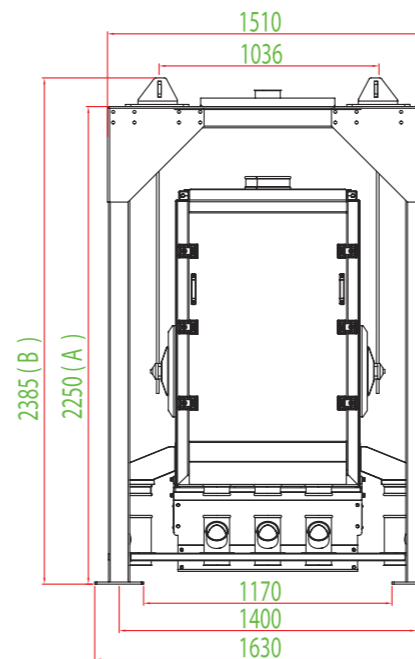
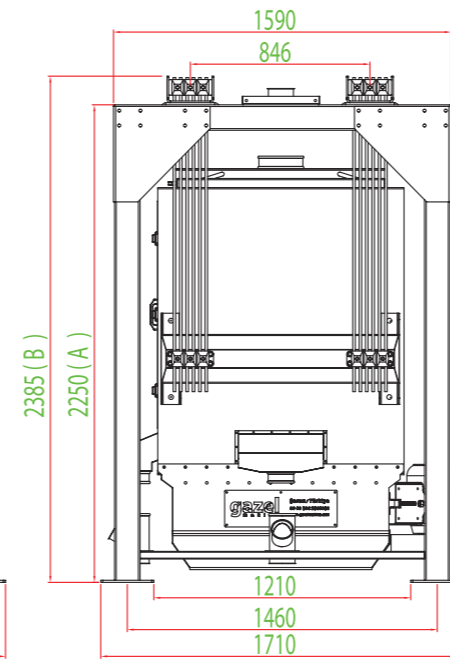
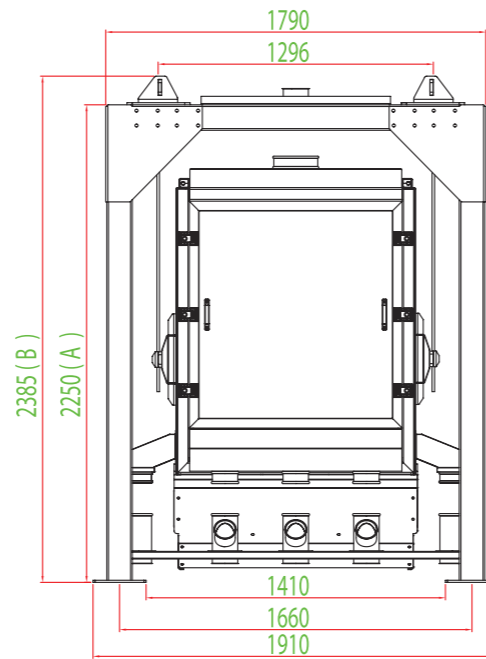

Tip Type	Pasaaj Sayısı Number of Section	Ölçüler Measures (mm)		Her Pasaajdaki Elek Sayısı Number of Sieves per Section	Toplam Kasa Yüksekliği Total Height of Sieves	Yaklaşık Eleme Alanı (m ²) Approximate Sifting Area (m ²)				Motor Devri Engine Speed (rpm)	Makine Devri Machine Speed (rpm)	Motor kw Engine kw	Makine Çalışma Dairesi Çapı Machine Working Circle Diameter (mm)	Yaklaşık Ağırlık Approximate Weight (KG)
		A	B			G TIP-W TYPE		N TIP-N TYPE						
						Max	Min	Max	Min					
GMA 1/8-740	1	2100	2085	8-4	89	2,83	1,41	2,28	1,14	1000	245	1,1	65	1010
GMA 1/12-740	1	2250	2385	12-8	119	4,24	2,83	3,42	2,28	1000	245	1,5	65	1080
GMA 1/8-1000	1	2100	2085	8-4	89	6,98	3,49	-	-	1000	245	1,5	65	1100
GMA 1/12-1000	1	2250	2385	12-8	119	10,47	6,98	-	-	1000	245	1,5	65	1400
GMA 2/8-740	2	2100	2085	8-4	89	5,65	2,83	4,56	2,28	1000	245	1,5	65	1450
GMA 2/12-740	2	2250	2385	12-8	119	8,48	5,65	6,84	4,56	1000	245	2,2	65	1750

