

STANDART
640 x 640 KASALI ELEK

STANDARD SIFTER
WITH 640 x 640 SIEVES

GM
Serisi
GM
Series

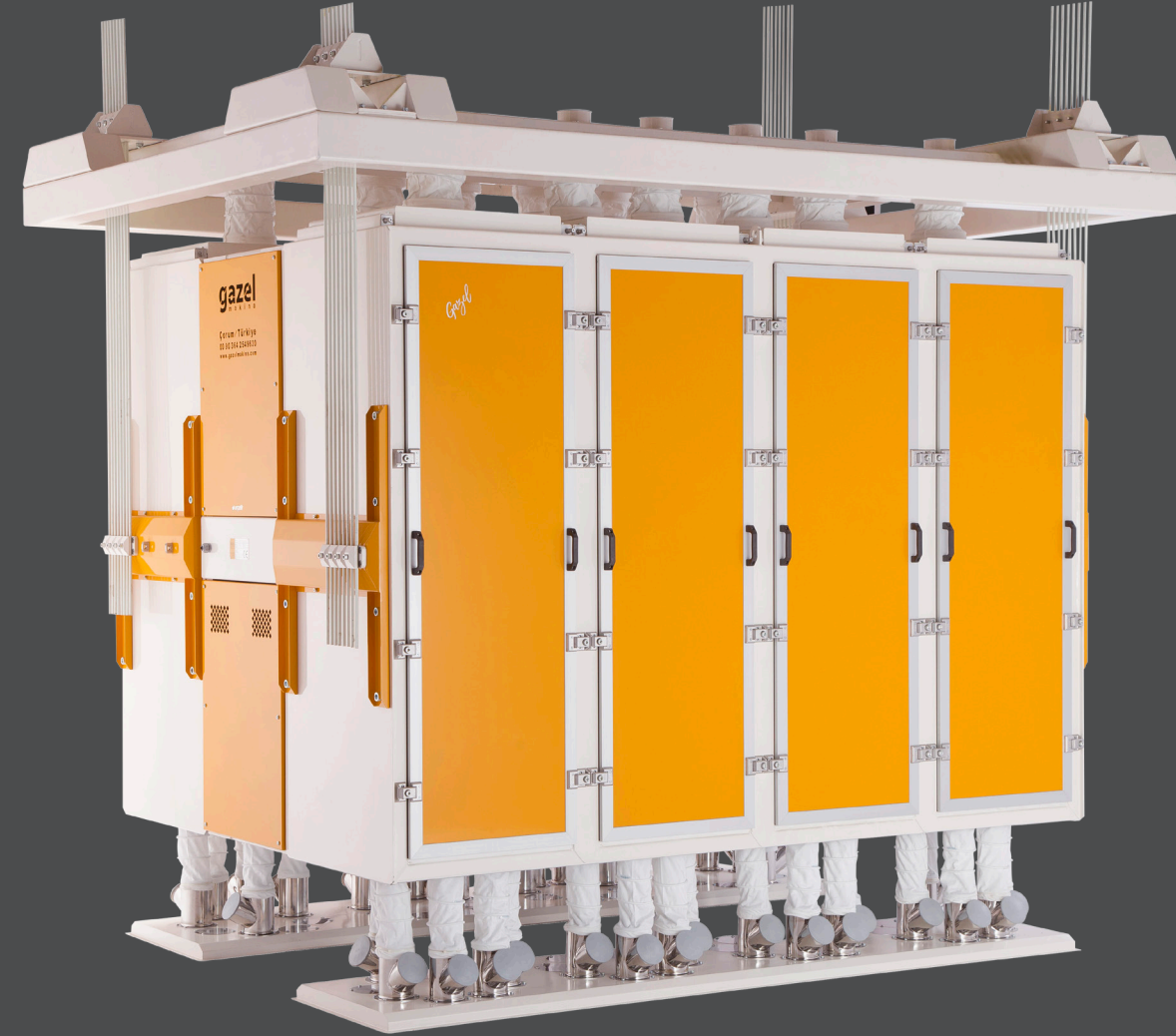

gazel
milling

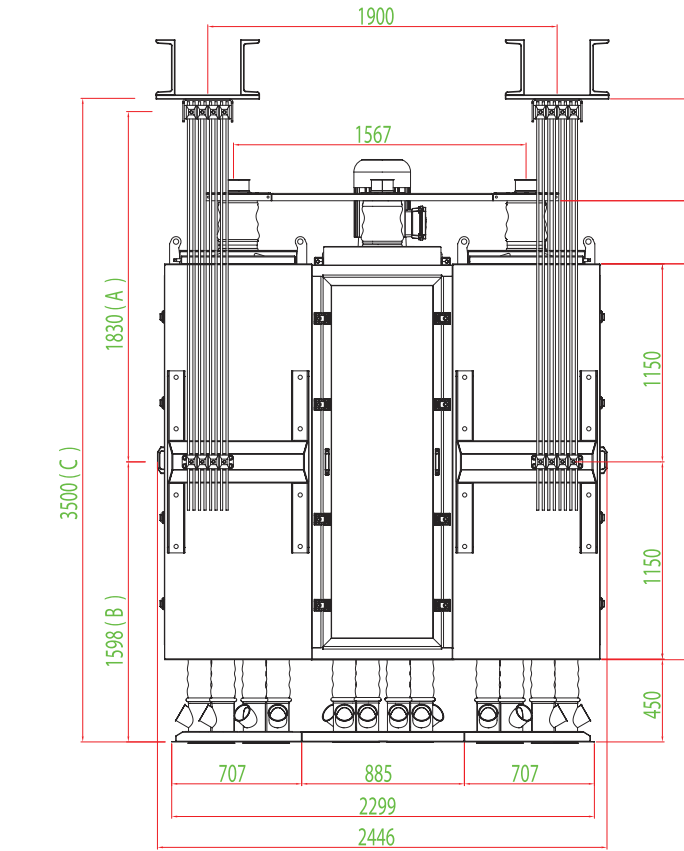
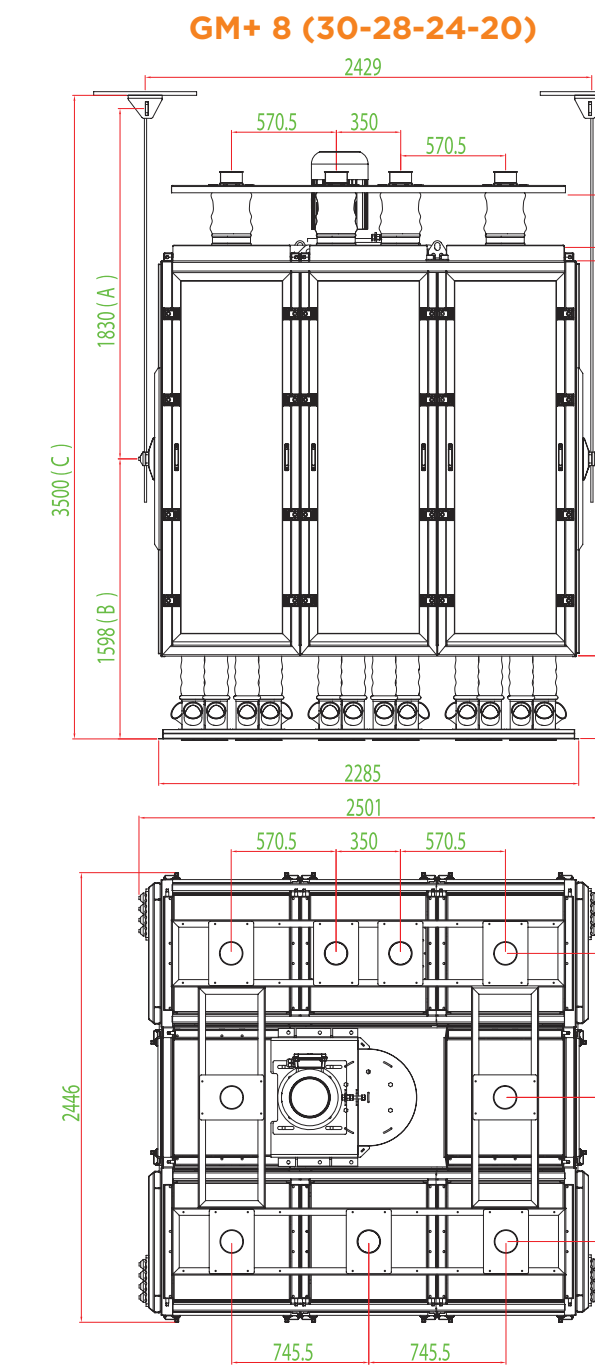
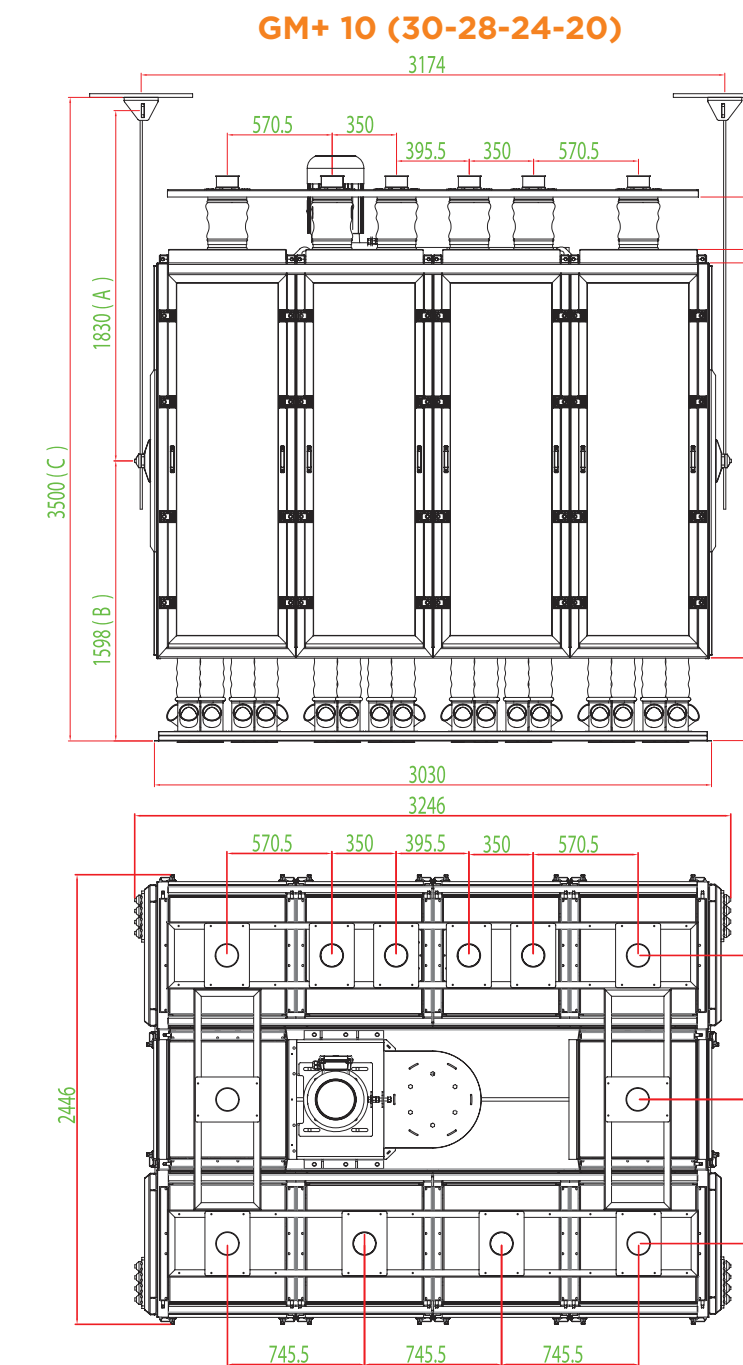
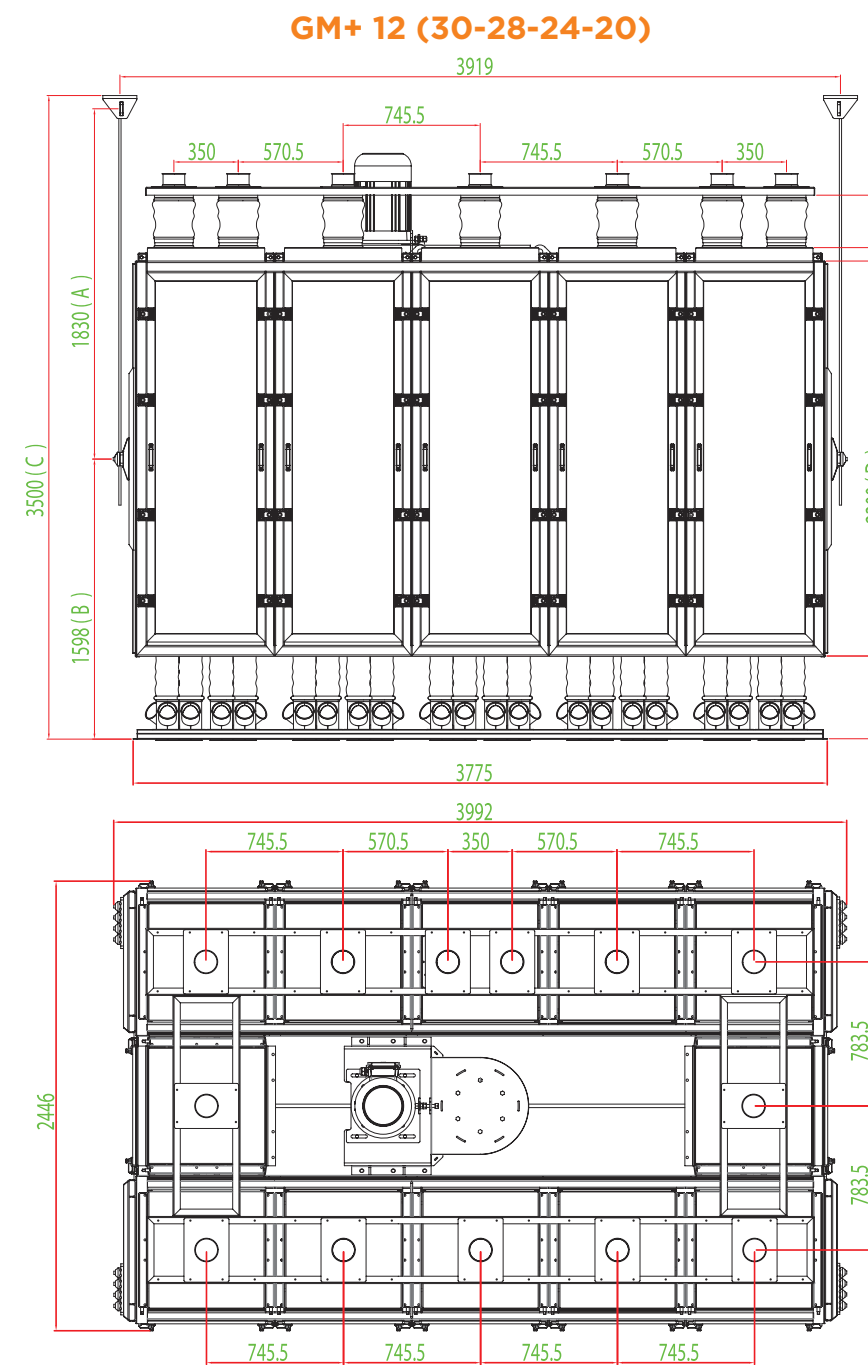

GM+ 12-10-8

Tip Type	Pasaaj Sayısı Number of Section	Ölçüler Measures (mm)				Her Pasaajdaki Elek Sayısı Number of Sieves per Section	Toplam Kasa Yüksekliği Total Height of Sieves	Yaklaşık Eleme Alanı (m ²) Approximate Sifting Area (m ²)				Motor Devri Engine Speed (rpm)	Makine Devri Machine Speed (rpm)	Motor kw Engine kw	Makine Çalışma Dairesi Çapı Machine Working Circle Diameter (mm)	Yaklaşık Ağırlık Approximate Weight (KG)
		A	B	C (min)	D			G TIP-W TYPE		N TIP-N TYPE						
								Max	Min	Max	Min					
GM+ 12 / 30	12	1830	1598	3500	2300	30-26	214	127,22	110,26	102,60	88,92	1000	245	11	65	7050
GM+ 12 / 28	12	1755	1523	3350	2150	28-24	199	118,74	101,78	95,76	82,08	1000	245	11	65	6850
GM+ 12 / 24	12	1605	1373	3050	1850	24-20	169	101,78	84,82	82,08	68,40	1000	245	11	65	6400
GM+ 12 / 20	12	1500	1223	2795	1550	20-16	139	84,82	67,85	68,40	54,72	1000	245	7,5	65	5990
GM+ 10 / 30	10	1830	1598	3500	2300	30-26	214	106,02	91,88	85,50	74,10	1000	245	7,5	65	5800
GM+ 10 / 28	10	1755	1523	3350	2150	28-24	199	98,95	84,82	79,80	68,40	1000	245	7,5	65	5620
GM+ 10 / 24	10	1605	1373	3050	1850	24-20	169	84,82	70,68	68,40	57,00	1000	245	7,5	65	5200
GM+ 10 / 20	10	1500	1223	2795	1550	20-16	139	70,68	56,54	57,00	45,60	1000	245	7,5	65	4800
GM+ 8 / 30	8	1830	1598	3500	2300	30-26	214	84,82	73,51	68,40	59,28	1000	245	5,5	65	4850
GM+ 8 / 28	8	1755	1523	3350	2150	28-24	199	79,16	67,85	63,84	54,72	1000	245	5,5	65	4650
GM+ 8 / 24	8	1605	1373	3050	1850	24-20	169	67,85	56,54	54,72	45,60	1000	245	5,5	65	4250
GM+ 8 / 20	8	1500	1223	2795	1550	20-16	139	56,54	45,24	45,60	36,48	1000	245	5,5	65	3850



GM+ SERİSİ
EKSTRA
PASAJLI
640 x 640

GM+ SERIES
EXTRA
SECTION
640 x 640

